

COMPRESSION LATCHES

E3-C VISE ACTION® Compression Latch

Zinc and plated steel housing · Tool operated
Adjustable grip · 19.1mm size · Compact

Features

- Minimal panel intrusion
- Consistent pre-set compression
- Easy grip adjustment
- Tool operated for security
- EN 45545-3 E10 compliant
- NEMA 4 and IP65 enabled using gasket supplied
- Order latch and cam separately

Material

- Zinc alloy, powder coated or chrome plated and steel, zinc plated

Product Performance

- Maximum static load: 450 N
- Recommended tightening torque for the mounting nut is 20 N.m

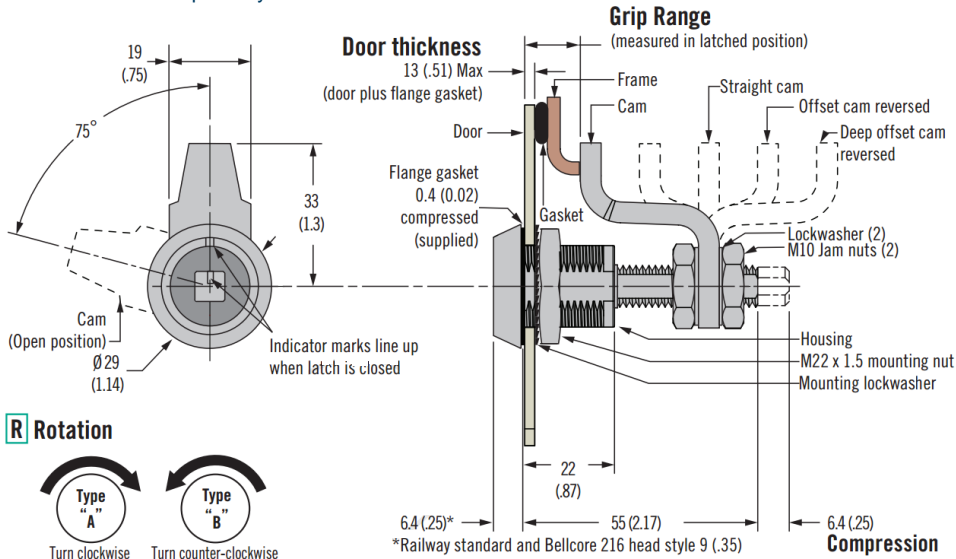

R Rotation

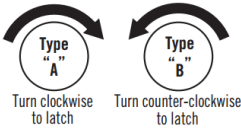

H Head Styles

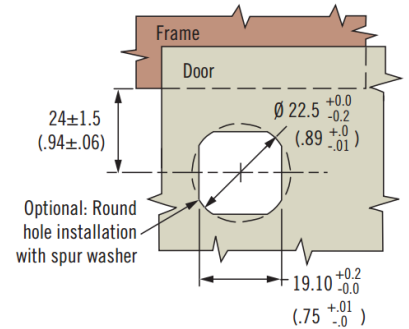
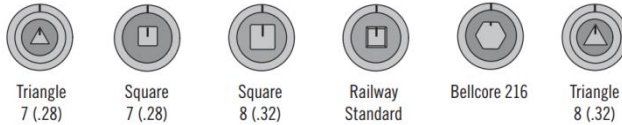

Latch Part Number (no cam)

E3 - C **R** **H** - O **F**

R Rotation

- 1 Type A clockwise to latch
- 22 Type B counter-clockwise to latch

H Head Style

- 3 7 (.28) Triangle
- 4 7 (.28) Square
- 10 8 (.32) Square
- 11 Railway standard
- 15 Bellcore 216
- 20 8 (.32) Triangle

F Finish

- 1 Chrome plated
- 5 Black powder coated
- 7 Silver powder coated

Cam Part Number Table (order separately from latch)

Minimum Grip	Maximum Grip	Part Number	Cam Type
3.3 (.13)	19 (.75)	Deep offset cam, forward	E3-28-201-12
58.6 (2.31)	67.5 (2.70)	Deep offset cam, reversed	
17 (.67)	32.7 (1.29)	Offset cam, forward	E3-28-202-12
44.4 (1.75)	60.1 (2.37)	Offset cam, reversed	
30.7 (1.21)	46.4 (1.83)	Straight cam	E3-28-203-12

E3-C VISE ACTION® Compression Latch

Zinc and plated steel housing · Tool operated
Fixed grip · 19.1mm size · Compact

Features

- Minimal panel intrusion
- Consistent pre-set compression
- Tool operated for security
- EN 45545-3 E10 compliant
- NEMA 4 and IP65 enabled using supplied gasket
- Order latch and cam separately

Material

- Zinc alloy, powder coated or chrome plated and steel, zinc plated

Product Performance

- Maximum static load: 300 N
- Recommended tightening torque for the mounting nut is 20 N.m, and for the mounting screw is 10 N.m



COMPRESSION LATCHES

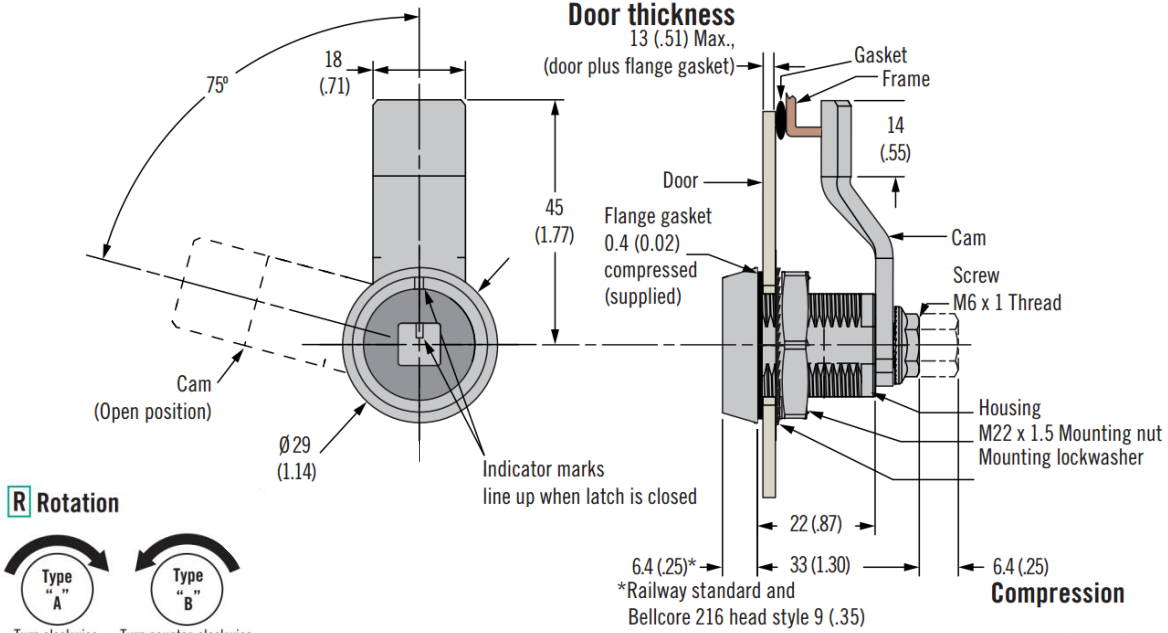

R Rotation

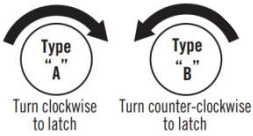

H Head Styles

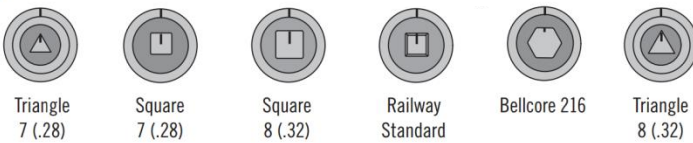

Latch Part Number (no cam)

E3 - C R H - UU F

R Rotation

- 12 Type A clockwise to latch
- 29 Type B counter-clockwise to latch

H Head style

- 3 7 (.28) Triangle
- 4 7 (.28) Square
- 10 8 (.32) Square
- 11 Railway standard
- 15 Bellcore 216
- 20 8 (.32) Triangle

F Finish

- 1 Chrome plated
- 5 Black powder coated
- 7 Silver powder coated

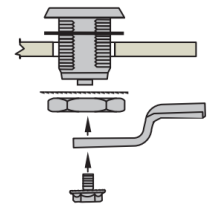
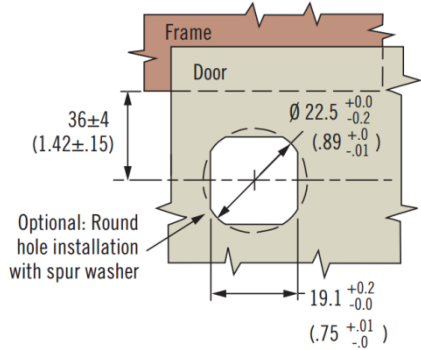

Cam Part Number (order separately from latch)

Grip	Part Number	Grip	Part Number	Grip	Part Number	Grip	Part Number
4 (.16)	E5-2500	14 (.55)	E5-2505	24 (.94)	E5-2510	34 (1.34)	E5-2515
6 (.31)	E5-2501	16 (.63)	E5-2506	26 (1.02)	E5-2511	36 (1.42)	E5-2516
8 (.31)	E5-2502	18 (.71)	E5-2507	28 (1.10)	E5-2512	38 (1.50)	E5-2517
10 (.39)	E5-2503	20 (.79)	E5-2508	30 (1.18)	E5-2513	40 (1.57)	E5-2518
12 (.47)	E5-2504	22 (.87)	E5-2509	32 (1.26)	E5-2514	42 (1.65)	E5-2519

Select smaller grip if your grip falls between two options in the Cam Table

southco®

E3 VISE ACTION® Compression Latch Accessories

Keys

Keys - Steel

For latches with *SOUTHCO*®
Tubular key head styles

Part Number

- 13.5mm size:
E3-26-819-15
- 19.1mm size:
E3-5-15

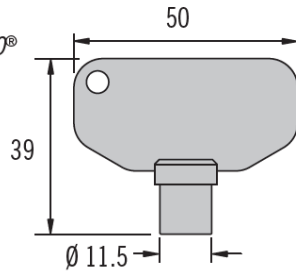

Keys - Zinc or Nylon

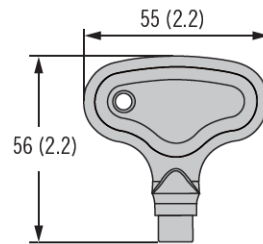

H Head style

- 2 3 (.11) Double bit
- 3 7 (.28) Triangle*
- 4 7 (.28) Square
- 7 8 (.32) Triangle
- 8 8 (.32) Square recess
- 9 5 (.19) Double bit
(nylon only)
- 10 8 (.32) Square male
(zinc only)
- 11 Bellcore electronics
- 12 Bellcore 216
(zinc only)
- 14 Railway Standard
(zinc only)

F Finish

- 1 Plated zinc
- 2 Natural zinc
- 3 Nylon black

E3 - H - F

Key Styles

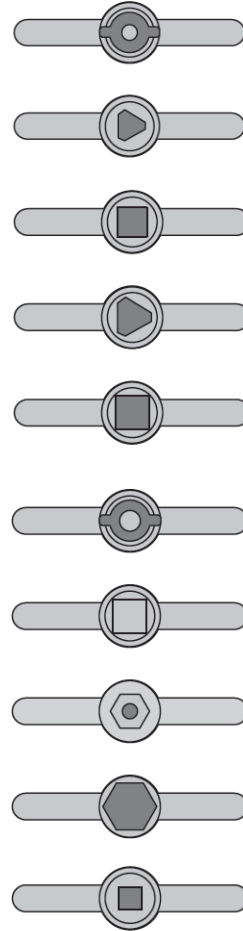

- 2 3 (.11) Double bit
- 3 7 (.28) Triangle
- 4 7 (.28) Square
- 7 8 (.32) Triangle
- 8 8 (.32) Square recess
- 9 5 (.19) Double bit
- 10 8 (.32) Square male
- 11 Bellcore electronics
- 12 Bellcore 216
- 14 Railway Standard

*Does not work with 7mm tapered triangle

Overmolded Keys

Key CH751



Key R001



Flat Keys

Key CH751



Part Number

- Overmolded key CH751:
 - Single: PK-10-10-05
 - Pair: PK-10-01-05
- Overmolded key R001:
 - Single: PK-10-10-05-KR001
 - Pair: PK-10-01-05-KR001
- Flat key
 - Pair: PK-10-01